



## Kielder Water Sailing Club

### Open Meeting

9th/10th September 2017

-

### Also an Osprey Open Meeting

## SAILING INSTRUCTIONS

### 1 RULES

- 1.1 The event will be governed by the 'rules' as defined in *The Racing Rules of Sailing 20017-2020 (RRS)*.

### 2 NOTICES TO COMPETITORS

- 2.1 Notices to competitors will be posted on the Official Notice Board in the Kielder Water Sailing Club clubhouse.
- 2.2 Any changes to the sailing instructions will be posted at least 1 hour before the scheduled warning signal of any race affected. Any change to the Racing Schedule for the Sunday will be posted on the Official Notice Board before 20.00 hrs on Saturday evening.

### 3 SIGNALS MADE ASHORE

- 3.1 Signals made ashore will be displayed at the Club signal mast.
- 3.2 When the AP flag is displayed ashore, the warning signal will be made not less than 20 minutes after flag AP is removed. **This changes the meaning of AP in Race Signals.**

### 4 PERSONAL FLOATATION

- 4.1 Flag Y will not be displayed. Personal Floatation Devices shall be worn at all times afloat and on the jetty. **This changes Rule 40.**

### 5 SCHEDULE OF RACES.

- 5.1 The number of races scheduled is as follows:

Day	Race	First Warning Signal
Saturday	Briefing	12:00
	Race 1	13:00
	Race 2	ASAP after race 1
	Race 3	ASAP after race 2
	Race 4	10:30
Sunday	Race 5	ASAP after race 4

Races will be sailed 'back to back' unless AP over H or AP over A is displayed at the finish line.

- 5.2 On the last day of the event no warning signal will be made after 15:00.

## 6 STARTING ORDER AND CLASS FLAGS

6.1 The starting order and class flags will be posted on the Official Notice Board before the Briefing.

## 7 SAILING AREAS.

7.1 The racing area will be Kielder Water. Boats shall not enter the prohibited areas marked as such on the map displayed in the clubhouse.

7.2 These areas rank as obstructions.

## 8 COURSES AND MARKS

8.1 The attached diagram shows the course for each class.

8.2 Each race will consist of 3 laps. In the case of the triangle/sausage course, a complete triangle and sausage constitutes one lap.

8.3 Marks 1, 2, 3 and 4 will be large cylindrical orange inflatable marks.

8.4 Boats **SHALL** sail through the Gate, between the committee boat and the outer distance mark, on each leg from Mark 4 to Mark 1.

## 9 THE START

9.1 Starts will be governed by **Rule 26** except that the time sequence will be 3-2-1-0. **This changes Rule 26.**

9.2 The Start line will be from the mast of the committee boat flying an orange flag to an orange outer distance mark with an orange flag.

## 10 THE FINISH

10.1 The Gate between the committee boat mast flying an blue flag and the outer distance mark will serve as the Finish Line, unless the course is shortened to a rounding mark under rule 32.2(a).

## 11 TIME LIMITS

11.1 There will be a time limit of 90 minutes for the leading boat. Boats not finishing within 30 minutes of the first boat will be scored 'Did not finish'. **This changes Rule 35.**

11.2 In the event of boats failing to finish within the time limit, results may be calculated on the basis of laps already completed. The decision to do this will be that of the Race Officer, which will be final. **This changes rules 35, A4.1 and A4.2.**

## 12 PROTESTS.

12.1 Protest forms are available at the race office.

12.2 Protest Time Limit. A protest shall be delivered to the race office not later than one hour after the last boat finishes the last race of that day.

12.3 Notice of Protests will be posted on the Official Notice Board no later than 10 minutes after the protest time limit, to inform competitors of the hearings to which they are parties or are named as witnesses.

12.4 Breaches of Sailing Instructions 4.1, 7.1 and 15 will not be grounds for a protest by a boat. **This changes rule 60.1(a).**

## 13 SCORING.

13.1 The series will be scored using the Low Point scoring system in Appendix A4 of the racing rules.

13.2 Two races or more will constitute a series

## 14 DISCARDS.

14.1 If three or more races are completed there will be one discard.

## 15 SAFETY REGULATIONS

15.1 Declaration sheets will be posted in the clubhouse.

15.2 Declaration sheets shall be signed within 1 hour of the finish of the last boat in the last race of the day. Any helm failing to sign the declaration sheet will be scored DSQ without a hearing. **This changes rule 63.1**

15.3 A boat that retires from a race or from the event shall notify the race committee as soon as possible.

## 16 REPLACEMENT OF CREW

16.1 Substitution of crew will not be allowed without the prior approval of the race committee.

## 17 BOAT IDENTIFICATION.

17.1 Distinguishing sail numbers shall be clearly visible. If sail numbers cannot be distinguished, a boat may be scored DNF without a hearing. **This changes rule 63.1**

1.2. A variation of sail numbers shall be notified to the Race Office and may be accepted by the Race Committee

**Course Diagrams (NOT to scale, all angles are approximate)**

**Osprey and Fast Handicap**

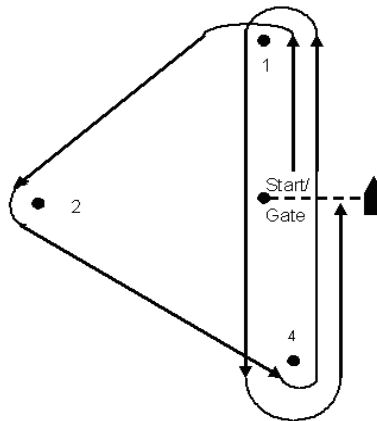

Start – 1 – 2 – 4 – Gate – 1 – 4 – Gate

3 Laps

**Slow Handicap and Junior**

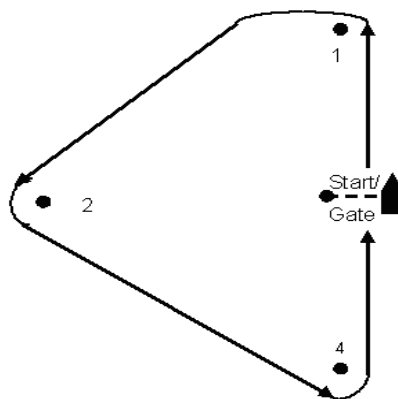

Start – 1 – 2 – 4 – Gate

3 laps